

**FURUNO**

# SATELLITE COMPASS



Models:  
SC-130  
SC-70

# High precision and accurate Heading of 0.25° Perfect for Radar, ECDIS, AIS, Doppler Sonar and Autopilot

The SC-70 and SC-130 are the latest satellite compasses, built on FURUNO's commercial-grade technology platform. These satellite compasses prove their value by increasing the accuracy of other instruments, such as Radar, Target Tracking (TT), ECDIS, AIS, Doppler Sonar and Autopilot.

They provide a highly accurate heading signal to these other technologies by utilizing the very latest GNSS (Global Navigation Satellite System). It is comprised of Galileo and GLONASS to ensure the highest precision.

The SC-70 and SC-130 provide a variety of data, including GPS Positioning, SOG (Speed Over Ground), COG (Course Over Ground), ROT (Rate Of Turn) and 3-axis speed (bow, stern and longitudinal). All of these data assist with critical maneuvers, such as berthing.

These Compasses are maintenance free and are a great asset for any vessel.



Standard High contrast 4.3" Color LCD  
(on the screen, the THD mode)  
SC-702

## SC-130 SC-70 FEATURES

### ► SC-130 features a Tri-sensor antenna that provides high accuracy for the heading of the ship

Provides highly accurate heading data for autopilot, Radar, Target Tracking, AIS, Doppler Sonar, and ECDIS.

- **0.25° (with SC-130)**

Ideal for medium to large ships navigating in crowded ports and making precise maneuvers, such as berthing.

- **0.4° (with SC-70)**

Ideal for small to medium ships requiring highly accurate heading

### ► Type-approved as THD, GPS and ROTI\*, complying with the following requirements

IMO MSC.116(73) • IMO MSC.112(73) • IMO MSC.526(13) • IMO A.694(17)  
IMO MSC.97(73) • IMO MSC.191(79) • IMO MSC.302(87) • IEC 60945 Ed.4  
IEC 62288 Ed.2 • IEC 61162-1 Ed. 4 • IEC 61162-2 Ed.1 • IEC 61162-450 Ed.1  
IEC 61108-1 Ed.2 • ISO 22090-3 Ed.2 • ISO 20672 Ed.1

\* requires the RD-50 as a display unit

### ► Utilizes GNSS such as Galileo and GLONASS for high precision

- SBAS compatible (EGNOS, WAAS, MSAS) highly accurate GPS, SBAS, Data – SOG, COG, ROT, and L/L
- Eliminating the problem of not having enough satellites at hand by using multiple types of satellite.

### ► Super short settling time - 90 seconds

### ► 100% free of regular maintenance, no recurring cost, no mechanical parts

### ► Easily integrated into the existing shipboard network via Ethernet

### ► Rapid follow-up rate 40°/s (twice the IMO high speed craft requirement, 20°/s)

### ► Precision Pitch/Roll data in Analog and Digital formats for Vessel Stabilizers, SONAR, etc.

### ► Bow and stern speed monitoring for safe berthing

### ► Easy to retrofit by using existing antenna cabling



# SATELLITE COMPASS

## SC-130 DISPLAY MODES SC-70

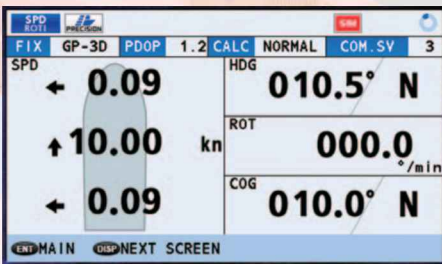

### Navigational data screen

- 3-axis speed, as well as the Heading, Rate Of Turn and Course Over Ground can be grasped at a glance (non-IMO type only)

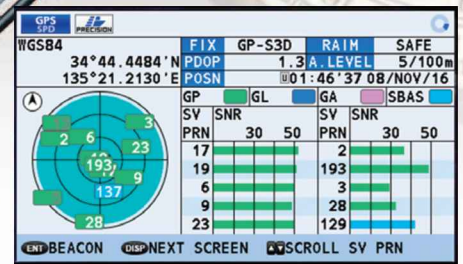

### GPS integrity mode

- GNSS (GPS, Galileo, GLONASS\*) satellites signal reception including signal strength and signal to noise ratio
  - SBAS signal status
- \*Not GLONASS type approved



- ① Current selected mode (SDME or THD), integrity status and common satellite number
- ② Transverse speed at bow position
- ③ Longitudinal speed
- ④ Transverse speed at stern position
- ⑤ Distance travelled

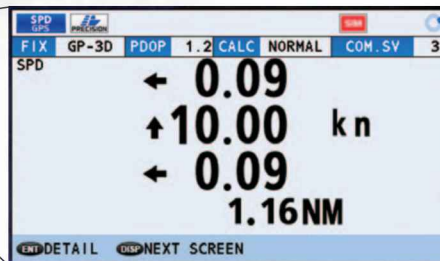

### Speed mode

- 3-axis speed of the ship : bow, stern and longitudinal (non-IMO type only)

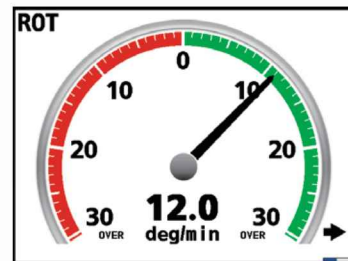

### ROTI display mode

- Rate Of Turn Indicator displaying on the RD-50

## SC-130 INTERCONNECTION DIAGRAM SC-70

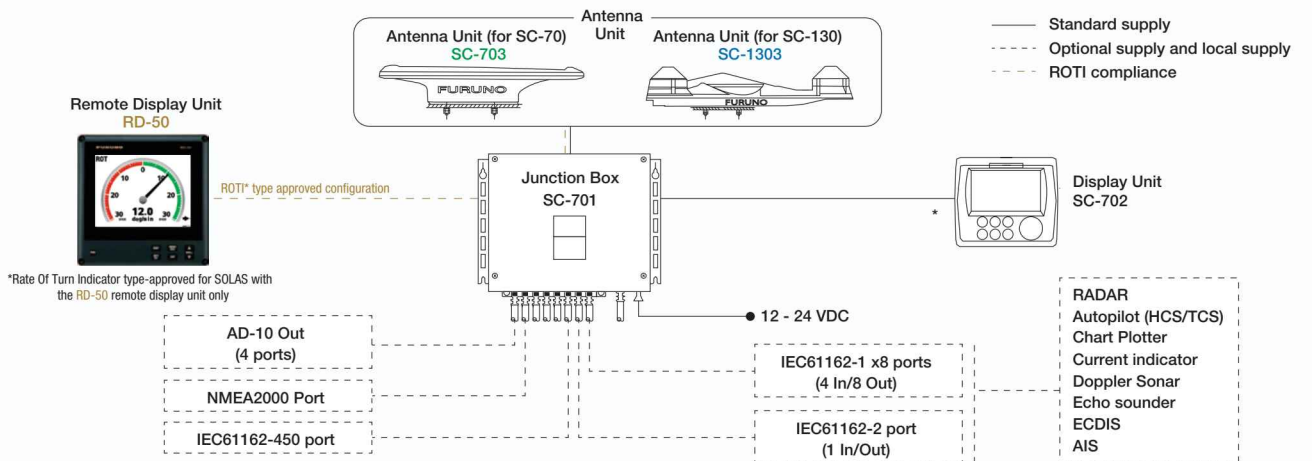

# SPECIFICATIONS

## GENERAL

Product Name	SATELLITE COMPASS
Reporting capacity	1575.42 MHz (GPS/GALILEO), 1602.5625 MHz (GLONASS)
Tracking code	C/A code (GPS), E1B (GALILEO), 10F (GLONASS)
Positional accuracy (dependent on ionospheric activity and multipath)	GPS 10 m approx. (2drms, HDOP<4) DGPS 5 m approx. (2drms, HDOP<4) WAAS 3 m approx. (2drms, HDOP<4) MSAS 7 m approx. (2drms, HDOP<4)
Ship's speed accuracy (SOG)	0.02 kn RMS (tracking satellites 5 or more)
Ship's speed accuracy (VBW, SOG)	0.2% of ship's speed or 0.02 kn whichever is the greater (tracking satellites 5 or more, at antenna unit)
Heading accuracy	SC-70 0.4° RMS, SC-130 0.25° RMS
Course resolution	0.1°, 0.01°, 0.001° typical (select from menu)
Tracking bearing	40°/s
Position fixing time	90 s approx. (typical)
Attitude accuracy	Pitch/Roll: 0.4° RMS
Attitude resolution	0.1°, 0.01°, 0.001° typical (select from menu)
Rate of turn	0.1°, 0.01°, 0.001°/min typical (select from menu)

## DISPLAY UNIT

Screen	4.3-inch color LCD, 95.04 mm (W) x 87.12 mm (H)
Resolution	480 x 272 dots (WQVGA)
Brilliance	600 cd/m <sup>2</sup> typical
Contrast	17 levels
Display mode	Heading, Nav data, Rate of turn and Speed modes (Non-IMO mode only)
Visible distance	0.65 m nominal

## INTERFACE (JUNCTION BOX)

<b>Number of ports (junction box)</b>	
IEC61162-2:	1 port (IN: 1, OUT: 1)
IEC61162-1:	8 ports (IN: 4, OUT: 8)
External beacon input (DATA5 port):	RTCM SC-104 V2.3 (RS-485), ITU-R M823
NMEA2000:	1 port
AD-10:	4 ports, for heading output
RS-485:	1 port, for display unit connection
LAN:	2 ports, Ethernet, 100Base-TX, RJ45 connector (IEC61162-450 and for maintenance)

### Data sentences

Serial data	Input	ACK, ACM, ACN, HBT, HDT*1, MSK, MSS, THS, VBW*2, VDR*2
	Output	ALC, ALF, ALR, ARC, DTM, GBS, GGA, GLL, GNS, GRS, GSA, GST, GSV, HBT, HDG*2, HDM*2, HDT*1, HRM*2, MSK, POS, RMC, ROT, THS, VBW*2, VDR*2, VHW*2, VLW*2, VTG, XDR*2, ZDA
Ethernet data	Input	ACK, ACM, ACN, HBT
	Output	ALC, ALF, ALR, ARC, DTM, GBS, GGA, GLL, GNS, GRS, GSA, GST, GSV, HBT, HDG*2, HDM*2, HDT*1, HRM*2, POS, RMC, ROT, THS, VBW*2, VDR*2, VHW*2, VLW*2, VTG, XDR*2, ZDA

### Output proprietary sentences

<b>PGN</b>	Input	059392/904, 060928, 061184, 126208/720/996
	Output	059392/904, 060928, 061184, 065280, 126208/464/720/992/996, 127250/251/252/257/258, 129025/026/029/033/044/291/539/540/545/547, 130310/312/314/316/577/578/822/823/842/843/845/846

### IEC61162-450 transmission group

	Input	MISC, SATD, NAVD, PROP
	Output	Arbitrary (default: SATD)

### Other network function excepted IEC61162-450

\*1: Not used for SOLAS vessels.  
\*2: for Non-IMO types only.

## POWER SUPPLY

Junction box	12-24 VDC: 2.1-1.1 A (included antenna unit and display unit)
Rectifier (PR-240, option)	100-115/220-230 VAC, 1 phase, 50-60 Hz and 24 VDC

## ENVIRONMENTAL CONDITIONS

Ambient temperature	Antenna unit -25°C to +55°C (storage: +70°C) Display unit/ Junction box -15°C to +55°C
Relative humidity	95% or less at +40°C
Degree of protection	Antenna unit IP56 Display unit IP22 (IP35: option) Junction box IP20 (IP22: bulkhead mount)
Vibration	IEC 60945 Ed.4

## EQUIPMENT LIST

Standard		Optional supply	
1	Antenna unit SC-703 x 1	1	Rectifier PR-240 x 1
	SC-1303 x 1	2	Alarm Monitoring IF-2503 x 1
2	Display Unit SC-702 x 1	3	Interface Unit IF-NMEA SC x 1
3	Junction Box SC-701 x 1	4	Remote Display RD-50 x 1
4	Installation Materials	5	Hanger OP26-8 x 1
		6	Connector MPS588-C x 1
		7	Water proof kit FRU-RJ-PLUG-ASSY x 1
		8	LAN_CNV kit x 2
		9	Signal cable x 1
		10	CAN cable M12-05BFFM-010/020/060 x 1
		11	Termination resistor (Micro) LTWMM-05AFFT-SL8001 x 1
		12	T-connector SS-050505-FMF-TS001 x 1

### Display unit (hanger)

SC-702 0.7 kg, 1.5 lb

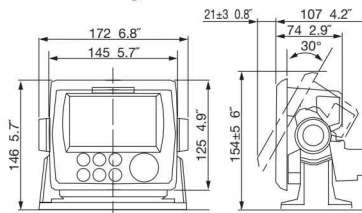

### Junction Box

SC-701 2.9 kg, 6.39 lb

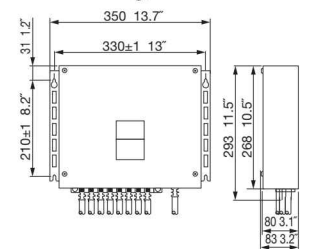

### Antenna unit

SC-1303 7.1 kg, 15.6 lb

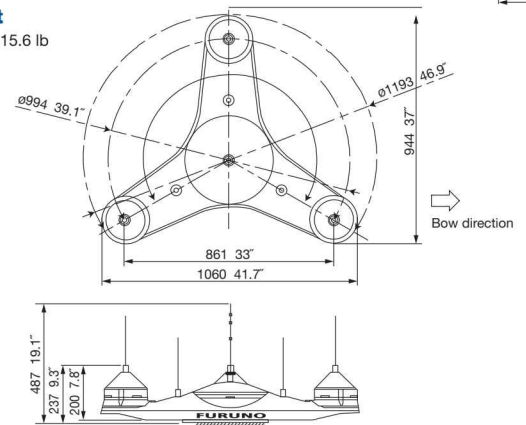

SC-703 2.8 kg, 6.17 lb

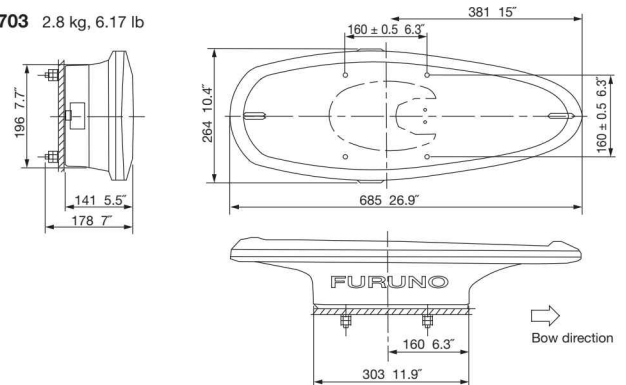

All brand and product names are registered trademarks, trademarks or service marks of their respective holders.  
SPECIFICATIONS SUBJECT TO CHANGE WITHOUT NOTICE

**FURUNO ELECTRIC CO., LTD.**  
Nishinomiya, Hyogo, Japan  
www.furuno.com

**FURUNO U.S.A., INC.**  
Camas, Washington, U.S.A.  
www.furunousa.com

**FURUNO (UK) LIMITED**  
Havant, Hampshire, U.K.  
www.furuno.co.uk

**FURUNO FRANCE S.A.S.**  
Bordeaux-Mérignac, France  
www.furuno.fr

**FURUNO ITALIA S.R.L.**  
Gatteo Mare, Italy  
www.furuno.it

**FURUNO ESPAÑA S.A.**  
Madrid, Spain  
www.furuno.es

**FURUNO DANMARK A/S**  
Hvidovre, Denmark  
www.furuno.dk

**FURUNO NORGE A/S**  
Ålesund, Norway  
www.furuno.no

**FURUNO SVERIGE AB**  
Västra Frölunda, Sweden  
www.furuno.se

**FURUNO FINLAND OY**  
Espoo, Finland  
www.furuno.fi

**FURUNO POLSKA Sp. z o.o.**  
Gdynia, Poland  
www.furuno.pl

**FURUNO EURUS LLC**  
St. Petersburg, Russian Federation  
www.furuno.com.ru

**FURUNO SINGAPORE PTE LTD**  
Singapore  
www.furuno.sg

**FURUNO DEUTSCHLAND GmbH**  
Rellingen, Germany  
www.furuno.de

**FURUNO HELLAS S.A.**  
Piraeus, Greece  
www.furuno.gr

**FURUNO (CYPRUS) LTD**  
Limassol, Cyprus  
www.furuno.com.cy

**FURUNO CHINA CO., LTD.**  
Hong Kong  
www.furuno.com/cn

**FURUNO SHANGHAI CO., LTD.**  
Shanghai, China  
www.furuno.com/cn

1-A-17023SK Printed in Japan  
Catalogue No. CA00001065